



# HD Series Industrial Steel Units

## Meets New York City Requirements

### Description

6 and 12 volt emergency lighting units in capacities up to 340 watts featuring traditional style, maintenance-free batteries and rugged steel construction.

### Features

- 6 and 12 volt models
- 85 to 340 watt capacities
- Heavy gauge steel cabinet in neutral cream finish
- Fully adjustable thermoplastic lighting heads with locking swivel assemblies
- Maintenance-free lead calcium battery standard
- 90 Minutes of emergency illumination
- Universal 120/277VAC input
- Fully automatic, temperature compensating, variable rate float charger standard
- Automatic low voltage battery disconnect protects battery from deep discharge
- Automatic brownout protection
- AC lockout feature reduces installation time
- Optional self-diagnostic circuit available
- Momentary test switch, AC ready and high charge indicators
- Meets NFPA Life Safety Code 101, NEC, OSHA, Local and State Codes
- UL924 listed



### Ordering Guide

Model No.	Volts	Watts For 1 1/2 Hrs.	Watts For 2 Hrs.	Watts For 3 Hrs.	Watts For 4 Hrs.	Standard Lamp	Weight (Lbs.)
HD-2	6	85	67	47	37	7.2W (-03)	35
HD-4	6	100	79	56	44	7.2W (-03)	40
HD-6	6	152	120	85	66	7.2W (-03)	60
HD-8	6	210	165	117	92	7.2W (-03)	75
12HD-13	12	170	134	95	74	9W (-51)	45
12HD-15	12	210	165	117	92	9W (-51)	65
12HD-17	12	340	268	190	149	9W (-51)	75

#### Options <sup>(1)(2)</sup>

Add Suffix	Description
-V	Voltmeter
-A	Ammeter
-LC1	3-Conductor Line Cord (120V)
-TD1	15-Minute Re-transfer Time Delay (120V)
-TD2	15-Minute Re-transfer Time Delay (277V)
-220	220V, 50Hz Input
-SX	Self-Diagnostic Circuit
-MH	Metal Lighting Heads
-B	Black Finish - Housing and Lighting Heads
-SP	Special Paint Finish - Specify Color

#### Accessories

Order Model	Description
B-1	Mounting Bracket (HD-2, 4, 6 and 12HD-13 models)
S-4	Mounting Shelf (HD-2, 4, 6 and 12HD-13 models)
S-5	Mounting Shelf (HD-8, 12HD-15 and -17 models)
PG-2	Wire Guard (all models)
900-W-03	Matching Remote Head-Single (6 Volt models) (6V, 7.2W)
900-W-51	Matching Remote Head-Single (12 Volt models) (12V, 9W)
901-W-03	Matching Remote Head-Double (6 Volt models) (6V, 7.2W)
901-W-51	Matching Remote Head-Double (12 Volt models) (12V, 9W)

**NOTE:** All product specifications shown are subject to change without notice.

(1) Other options available. Consult factory.

(2) Some options may impact product UL listing. Consult factory.

### Specifier Reference

Project: \_\_\_\_\_

Fixture Type: \_\_\_\_\_

Model No.: \_\_\_\_\_

Comments: \_\_\_\_\_

## Construction

**Housing:** Heavy duty steel cabinet is finished in neutral cream baked-on powder paint providing scratch and corrosion resistance. Optional black (-B) and special color paint (-SP) finishes available, see Options on front for ordering details.

**Lighting Heads:** Impact resistant, UV stable, flame rated thermoplastic lamp housing and swivel assemblies in neutral cream color to match unit housing. Lighting heads are fully adjustable and feature lockable swivels.

## Installation

**Mounting:** Units are designed for mounting to walls by means of keyhole slots provided in the back of the unit housing. Units may also be mounted by means of accessory wall bracket or mounting shelf. See Ordering Guide on front for details.

**Wiring:** Surface wiring is provided for by conduit knockouts in the left hand side of the unit housing.

## Illumination

High output incandescent lamps maximize illumination characteristics through a specially designed reflector and glass lens assembly that provides glare-free trapezoidal light distribution.

**Lamp Type 6 and 12V models:** Incandescent - wedge base

**6 Volt Lamp Rating:** 6 volt, 7.2 watt

**12 Volt Lamp Rating:** 12 volt, 9 watt

**Lamp Life:** 100 hours (expected average)

## Code Information

All models are UL924 Listed and meet NFPA 101 Life Safety Code, NEC, OSHA, Local and State Codes

## Charger and Electronics

**Charger Type:** Fully automatic, temperature compensating, variable rate float charger

**Utility Input:** 120/277VAC, 60 Hz.

**Power Consumption:** 15 watts (maximum)

**Temperature Range:** 68°F to 86°F (20°C to 30°C)

**Recharge Duty Cycle:** 24 hours

**Load Transfer:** All models utilize mechanical relays for load transfer and provide fused DC load connections.

**Controls:** Momentary test switch, LED AC-On and high charge indicator lights

**Safety Circuitry:**

**AC Lockout:** Prevents battery discharge prior to initial unit power-up saving installation time.

**Low Voltage Battery Disconnect:** Protects the battery from being severely damaged by deep discharge during prolonged power failures.

**DC Overload and Short Circuit Protection:** Provided by fused output connections.

**Brownout Protection:** Automatically switches the unit to emergency mode when utility voltage is reduced to the point at which most fluorescent light fixtures would extinguish.

## Emergency Operation

Upon failure of the normal utility power, a solid-state transfer switch automatically connects the unit's battery to the emergency lamp. Emergency illumination will be supplied for a minimum of 90 minutes. During emergency operation, the unit battery is protected from severe discharge damage by an automatic low voltage disconnect circuit that discontinues unit operation when battery voltage reaches 87.5% of nominal. When normal utility power is restored, the battery is automatically disconnected from the load and a recharging cycle begins that will return the battery to full capacity within 24 hours.

## Dimensions

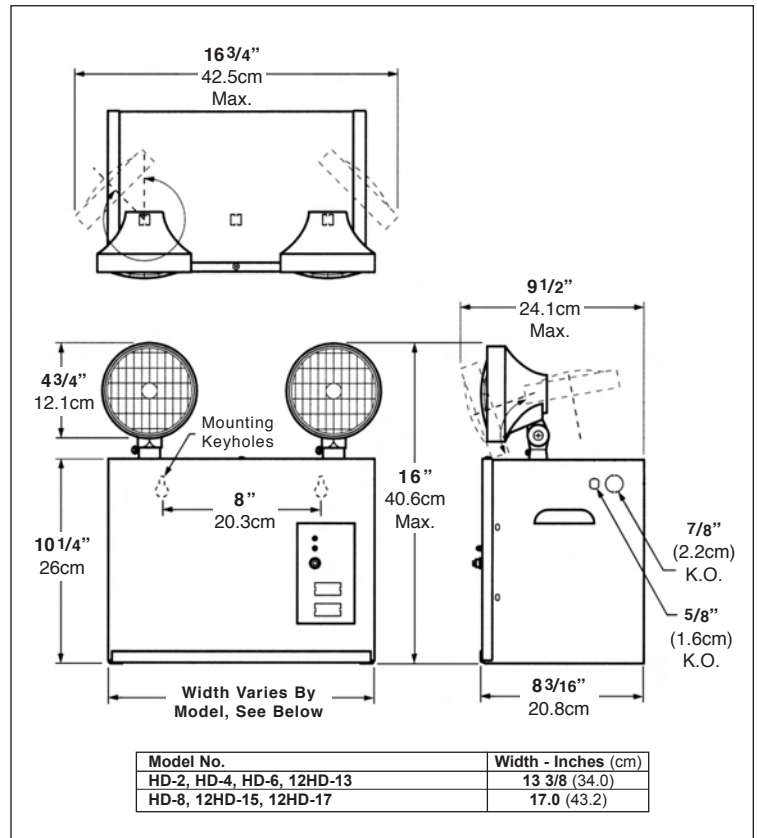

## Optional Self-Diagnostic Circuit

The optional SX self-diagnostics circuit automatically cycles the emergency lighting unit every 25-30 days. The SX circuit checks for battery charging and over charging, battery capacity and reports any system malfunction. By design the SX does not activate the lighting heads, thus avoiding substantial lamp life reduction.

## Battery

Sealed lead calcium maintenance free battery designed to provide many years of dependable service.

## Warranty

**Unit:** (excluding lamps) 3-years full coverage against defects in materials and workmanship from date of shipment

**Battery:** 3 years full warranty plus an additional 7 years of pro-rata coverage