



IS Series Environmental Steel Units

Meets New York City Requirements



Description

6 and 12 volt emergency units designed for use in dusty or dirty areas. Units feature rugged steel enclosures, gasketed construction and sealed lighting heads.

Features

- 6 and 12 volt models
- Sealed and gasketed construction
- Provides protection against dust, dirt, lint, fibers and light splashing by noncorrosive liquids
- Heavy gauge NEMA 3R type steel enclosure in industrial gray finish
- Fully adjustable thermoplastic lighting heads with locking swivel assemblies
- Maintenance-free lead calcium battery standard
- Optional nickel cadmium battery available
- 90 Minutes of emergency illumination
- Universal 120/277VAC input
- Fully automatic, temperature compensating, variable rate float charger standard
- Automatic low voltage battery disconnect protects battery from deep discharge
- Automatic brownout protection
- AC lockout feature reduces installation time
- Optional self-diagnostic circuit available
- Momentary test switch and AC ready indicator
- Meets NFPA Life Safety Code 101, NEC, OSHA, State and local Codes
- UL924 listed

Ordering Guide

Model No.	Volts	Watts For 1 1/2 Hrs.	Watts For 2 Hrs.	Watts For 3 Hrs.	Watts For 4 Hrs.	Standard Lamp	Weight (Lbs.)
Lead Calcium Battery Models							
IS-3	6	16	12	8	7	7.2W (-10)	17
IS-5	6	26	20	14	11	7.2W (-10)	20
IS-7	6	32	25	17	14	7.2W (-10)	22
IS-9	6	52	41	29	22	7.2W (-10)	24
12IS-12	12	32	25	17	14	12W (-59)	22
12IS-14	12	52	41	29	22	12W (-59)	24
Nickel Cadmium Battery Models							
ISN-3	6	16	12	8	7	7.2W (-10)	17
ISN-5	6	26	20	14	11	7.2W (-10)	20
12ISN-12	12	30	23	16	13	12W (-59)	22
12ISN-14	12	52	41	29	22	12W (-59)	24
Options ⁽¹⁾⁽²⁾							
Add Suffix	Description						
-LCW	Weatherproof 3-Conductor Line Cord (120V)						
-TD1	15-Minute Re-transfer Time Delay (120V)						
-TD2	15-Minute Re-transfer Time Delay (277V)						
-220	220V, 50Hz Input						
-SX	Self-Diagnostic Circuit						
-MH	Metal Lighting Heads						
-16	8 Watt Halogen Lamps (6V models only)						
-63	8 watt Halogen Lamps (12V models only)						
-W	White Finish - Housing and Lighting Heads						
-SP	Special Paint Finish - Specify Color						
Accessories							
Order Model	Description						
PG-2	Wire Guard						
927-G-10	6 Volt Matching Remote Head-Single (6V, 7.2W)						
927-G-10	6 Volt Matching Remote Head-Double (6V, 7.2W)						
927-G-59	12 Volt Matching Remote Head-Single (12V, 9W)						
927-G-59	12 Volt Matching Remote Head-Double (12V, 9W)						

NOTE: All product specifications shown are subject to change without notice.

(1) Other options available. Consult factory.

(2) Some options may impact product UL listing. Consult factory.

Specifier Reference

Project: _____

Fixture Type: _____

Model No.: _____

Comments: _____

Construction

Housing: Heavy duty steel NEMA 3R type cabinet is completely sealed and gasketed and finished in industrial gray. Optional white (-W) and special color paint (-SP) finishes available, see Options on front for ordering details.

Lighting Heads: Impact resistant, UV stable, flame rated thermoplastic lamp housing and swivel assemblies in gray finish to match unit housing. Heads and swivels are sealed and gasketed. Lighting heads are fully adjustable and feature lockable swivels.

Installation

Mounting: Units are designed for installation to wall surfaces by means of four mounting tabs provided on the enclosure.

Wiring: Knockouts are provided on the left hand side of the enclosure for attachment of surface wiring or conduit.

Illumination

High output incandescent lamps maximize illumination characteristics through a specially designed reflector and glass lens assembly that provides glare-free trapezoidal light distribution.

Lamp Type: Incandescent - Par 36 sealed beam

6 Volt Lamp Rating: 6 volt, 7.2 watt

12 Volt Lamp Rating: 12 volt, 9 watt

Lamp Life: 100 hours (expected average)

Code Information

All models are UL924 Listed and meet NFPA 101 Life Safety Code, NEC, OSHA, Local and State Codes

Charger and Electronics

Charger Type: Fully automatic, temperature compensating, variable rate float charger

Utility Input: 120/277VAC, 60 Hz.

Power Consumption: 15 watts (maximum)

Temperature Range: 68°F to 86°F (20°C to 30°C)

Recharge Duty Cycle: 24 hours

Load Transfer: 6 volt models rated 25 watts or less and 12 volt models rated 50 watts or less utilize a solid state transfer circuit for load connection. All other models utilize mechanical relays for load transfer and provide fused DC load connections.

Controls: Momentary test switch and LED AC-On indicator light
Safety Circuitry:

AC Lockout: Prevents battery discharge prior to initial unit power-up saving installation time.

Low Voltage Battery Disconnect: Protects the battery from being severely damaged by deep discharge during prolonged power failures.

DC Overload and Short Circuit Protection: On units with solid state transfer, output protection is provided by a disconnect circuit that automatically resets itself when the fault condition is corrected. On units with mechanical relay transfer, output protection is provided by fused load connections. See Load Transfer above for details.

Brownout Protection: Automatically switches the unit to emergency mode when utility voltage is reduced to the point at which most fluorescent light fixtures would extinguish.

Dimensions

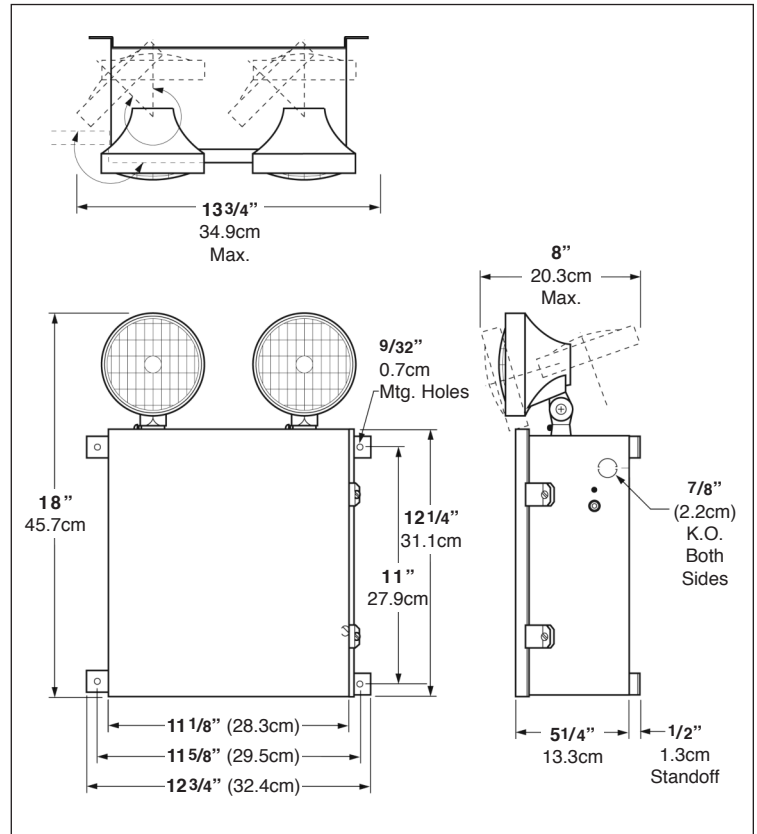

Emergency Operation

Upon failure of the normal utility power, a solid-state transfer switch automatically connects the unit's battery to the emergency lamp. Emergency illumination will be supplied for a minimum of 90 minutes. During emergency operation, the unit battery is protected from severe discharge damage by an automatic low voltage disconnect circuit that discontinues unit operation when battery voltage reaches 87.5% of nominal. When normal utility power is restored, the battery is automatically disconnected from the load and a recharging cycle begins that will return the battery to full capacity within 24 hours.

Optional Self-Diagnostic Circuit

The optional SX self-diagnostics circuit automatically cycles the emergency lighting unit every 25-30 days. The SX circuit checks for battery charging and over charging, battery capacity and reports any system malfunction. By design the SX does not activate the lighting heads, thus avoiding substantial lamp life reduction.

Battery

Standard Battery: Sealed lead calcium maintenance free battery designed to provide many years of dependable service.

Optional Battery: Longest life nickel cadmium

Warranty

Unit: (excluding lamps) 3-years full coverage against defects in materials and workmanship from date of shipment

Battery: 3 years full warranty plus an additional 7 years of pro-rata coverage